



IWG News



The Newsletter of the Island Woodturners Guild

March 2026

About the IWG:

The [Island Woodturners Guild](#) meets from 1:00 - 4:00 PM on the 4th Saturday of each month (except for July/Aug) at the Central Saanich Senior Citizens' Centre, [1229 Clarke Road](#), Brentwood Bay, BC.

Visitors are welcome.

Executive Committee

President:

Hovan Baghdassarian

Vice President:

Virginia Lee

Treasurer:

Chris Leach

Secretary:

Michael McEwan

Members at Large:

Tim Karpiak

Harvey Pfluger

David Blair

Past President:

Don Costello

Newsletter Editor:

Virginia Lee

The IWG gratefully acknowledges the support of the following companies:

[Artisan Wood to Works](#)

[Chipping Away](#)

[Industrial Plastics & Paints](#)

[Island Blue Print](#)

[KMS Tools](#)

[PJ White Hardwoods](#)

[Richelieu Hardware](#)

[William Wood-Write](#)

THE PRESIDENT'S TURN

Hey everyone,

This year has been flying by and we find ourselves at the end of March already. I hope that you have been enjoying our guest demonstrators and we will keep that streak alive by having another one this month. On Saturday we will be joined by Jeff Hornung, a very accomplished turner if you want to check out his website. For his demo this month he will be showing us how to turn a bronze bowl and you can find some beautiful examples on his site. This is definitely a demo you will not want to miss.

I am guessing that many of you are early risers, but hopefully with this permanent change to daylight savings time we can all enjoy some nice sunny evening turning. As the weather gets warmer and my shop feels nicer it certainly encourages me to get out and turn more. This month I will be taking on a new challenge, teaching my teenage son to turn a bowl. He is taking woodworking in school and needs to do a project and that is what he wants to try. I have never taught anyone wood turning, let alone a teenager, but I am looking forward to it. Hopefully it goes well and if anyone has any tips please send them my way.

Just a reminder that after this meeting we only have 3 more guild meetings before the end of the year break for summer. The AGM will be taking place in May as it always does, so mark that on your calendar. As an executive we have been trying to think of ways to bring in new members to the guild and we are starting to see new people show up on Saturdays. Please do your best to make them all feel welcome and included so that we can continue to grow as a group.

Wishing you all the best start to spring!!

Parting off,

Hovan

NEXT MEETING: SATURDAY MARCH 28th: 1:00 p.m.



JEFF HORNUNG

Jeff Hornung will be demonstrating his techniques to embellish a turning to look like a bronze bowl using reactive metallic paints in an interactive remote demo. He will discuss the use of paints as well as form, chucking options and techniques to create the illusion of a weathered bronze piece. The link to the Teams meeting will be sent out on Thursday, March 26th.

RECAP OF FEBRUARY DEMONSTRATION



ART LIESTMAN

Art gave an **in**-person demonstration on the design and construction of teapots - The presentation primarily focused on various images of wooden teapots, accompanied by discussions on different methods of constructing them. The aim was to inspire members to think creatively and explore the various techniques that woodturners have employed.

Please note that no turning took place during this session. The content was designed to be clear and accessible for all members. You can view the video and transcript on our website [HERE](#): You will have to log in to view the video.

MARCH CHALLENGE

CHALLENGES: Guild challenges in the past have been a fun way of inspiration.

MARCH CHALLENGE: Tim has challenged us to turn a hollowform from the bottom. Bring in your failures too!

INPUT NEEDED: SUGGESTION FOR JUNE MEETING

We are putting together a list of topic ideas for our June meeting, which will feature **short, hands-on demonstrations** covering techniques of interest to turners at all levels. Some initial ideas include:

- **Workholding options:** types of chucks, jam chucks, and tail centers—when and why to use each

- **Lathe tools:** which gouges to use for different cuts and forms
- **Tenons:** how to turn strong tenons and effective methods for removing them
- **Jigs:** common shop-made jigs and how they can improve accuracy and safety
- **Indexing wheels:** what they are and practical ways to use them
- **Wood defects:** what to watch for and deciding when to turn through a flaw—or turn it into a feature

If there's something you've always wondered how to do, we'd love to hear from you. Email your questions or topic ideas to webmaster@islandwoodturners.com, and we'll add them to the list. Submissions are anonymous—so there are truly no stupid questions.

101 WOODTURNING COURSE

Are you or someone you know interested in taking the IWG 101 Woodturning course this fall? Email Don Costello (don@teamwhoswho.com) for more information and to get your name on the list. If you would like to be an instructor, let us know.

NEWBIES' CORNER

Embellishing Turned Wood: Burning, Staining & Carving

From Simple Accents to Artistic Statements

Once your piece is turned and sanded, the creative journey doesn't have to end. Embellishments like burning, staining, and carving can transform a well-made piece into a one-of-a-kind work of art. Whether you're working with a freshly turned maple bowl or experimenting with other woods, this guide walks you through the possibilities—from subtle accents to bold textures—while keeping safety and skill-building front and center.

Safety First: Before You Embellish

Each embellishment technique comes with its own risks. Here's how to stay safe:

- **Ventilation:** Burning and staining release fumes—work in a well-ventilated area or use a fume extractor.
- **Protective Gear:** Wear a dust mask when carving or sanding, and gloves when handling stains or dyes.

- **Fire Safety:** Keep a fire extinguisher nearby when using pyrography tools. Never leave them unattended.
- **Tool Awareness:** Sharp carving tools and hot burners demand full attention. Avoid distractions and fatigue.

Starting Simple: Easy Embellishments for Beginners

Burned Accents (Pyrography)

- **Tools Needed:** Basic woodburning pen or pyrography tool
- **Technique:** Add simple lines, dots, or geometric patterns around the rim or base.
- **Best Woods:** Maple is excellent—it burns cleanly and shows crisp detail.
- **Tips:**
 - Practice on scrap first.
 - Use light pressure and let the heat do the work.
 - Keep your strokes consistent for even depth and tone.

Precision Wire Burning: Clean Rings with Classic Charm

Wire burning is one of the simplest yet most striking embellishments you can add to a turned piece. It creates crisp, dark rings that contrast beautifully against lighter woods like maple, and it's especially effective on bowls, boxes, and spindle work.

What You'll Need

- **Burning Wire:** High-tensile steel wire, guitar string (e.g., E or G string), or purpose-made wire burning tools
- **Gloves or Handles:** To protect your hands from heat—some setups include wooden handles or dowels
- **Lathe Running at Moderate Speed:** Typically 500–1000 RPM

Safety First

- **Wear Gloves:** The wire gets hot quickly—protect your fingers.
- **Keep Hair and Clothing Clear:** You'll be leaning in close to the spinning piece.
- **Don't Overburn:** Excessive heat can scorch beyond the ring and damage the wood.

Technique: How to Burn a Ring

1. **Mark the Location:** Use a pencil to lightly mark where you want the ring.
2. **Start the Lathe:** Set it to a moderate speed—fast enough to generate friction, but slow enough to stay in control.
3. **Apply the Wire:** Hold the wire firmly at both ends and press it into the spinning wood at the marked location.
4. **Let Friction Do the Work:** The wire will begin to smoke and burn a groove. Hold steady until the ring is dark and even.
5. **Release Gently:** Don't yank the wire away—ease off to avoid tearing fibers.

Tips for Clean Results

- **Use a Groove First:** Cut a shallow groove with a parting tool before burning—this helps the wire stay in place and creates a crisper edge.
- **Multiple Rings:** Space them evenly for a classic look, or vary spacing for a more artistic effect.
- **Layer with Other Techniques:** Burned rings pair beautifully with staining or carving—use them to frame or divide visual zones.

Staining & Dyes

- **Purpose:** Enhance grain, add contrast, or introduce color.
- **Types:**
 - *Water-based dyes:* Bright colors, easy to blend.
 - *Alcohol-based stains:* Fast drying, deep penetration.
 - *Gel stains:* Good for controlled application.
- **Tips:**
 - Apply after sanding but before finishing.
 - Use masking tape to protect areas you want to keep natural.
 - Test on scrap to see how maple absorbs the stain—it can blotch if over-applied.

Texturing with Simple Carving

- **Tools Needed:** V-tool, micro gouge, or rotary burr

- **Technique:** Add shallow grooves, fluting, or stippling.
- **Tips:**
 - Start with symmetrical patterns—like radial lines or concentric rings.
 - Use a pencil to sketch your design before carving.
 - Keep your tools sharp and your hands steady.

Intermediate Techniques: Adding Depth & Drama

Advanced Pyrography

- Create shading, feathering, or realistic textures (like leaves or bark).
- Use variable-temperature burners for tonal control.
- Combine with carving for mixed-media effects.

Layered Staining

- Apply multiple colors in stages—e.g., a dark base followed by a lighter topcoat.
- Use steel wool or fine sandpaper between layers to reveal grain highlights.
- Try masking off geometric shapes for a stained inlay effect.

Relief Carving

- Carve deeper patterns that stand out in three dimensions.
- Ideal for decorative rims or focal medallions.
- Use gouges, chisels, and mallets for controlled depth.

Tips for Success

- **Design with Purpose:** Embellishments should complement the form, not compete with it.
- **Balance Texture and Finish:** Too much texture can overwhelm a glossy finish—consider matte or satin for carved pieces.
- **Practice First:** Always test your technique on scrap wood before applying it to your final piece.
- **Keep It Clean:** After embellishing, remove dust and residue before applying your final finish.

- **Document Your Process:** Take notes on what works—tool settings, stain brands, carving depths. It'll save you time later.

🎨 Finishing Embellished Pieces

Once your embellishments are complete, choose a finish that enhances them:

- **Oil + Wax:** Great for carved or burned surfaces—adds warmth without obscuring detail.
- **Shellac:** Seals stained wood beautifully and dries fast.
- **Spray Lacquer:** Ideal for textured surfaces—won't clog grooves like brushed finishes.
- **Water-Based Poly:** Clear and non-yellowing—perfect for preserving bright dye work.

🔚 Final Thoughts

Embellishing your turned pieces is where craftsmanship meets artistry. Whether you're adding a simple burned line or carving a dramatic relief, each technique offers a new way to express your style. Start small, stay safe, and let your creativity evolve with every bowl, box, or platter.

A.M. Turner – Bio



Nestled in the serene forests of Vancouver Island, **A.M. Turner** is an artisan, storyteller, and master of craftsmanship. With a cozy workshop filled with well-loved tools and the scent of fresh cedar, Turner finds magic in the details and loves to share them with others who are interested in the delicate art of turning wood and the quiet beauty of handmade things. A.M. Turner celebrates the connection between craft and storytelling, inviting readers and

woodworkers alike into a world where imagination and tradition intertwine.

TRICKS & TIPS

Carpet pad helps shape bowl bottoms

--Robert Shea, Santa Maria, Calif.

Cutting the relief in the bottom of a turned bowl is easy now that I've developed a padded faceplate. I mounted a large 3/4" plywood disc to a standard lathe faceplate. Then, using contact cement, I glued a piece of foam carpet pad to the front side of the plywood disc.

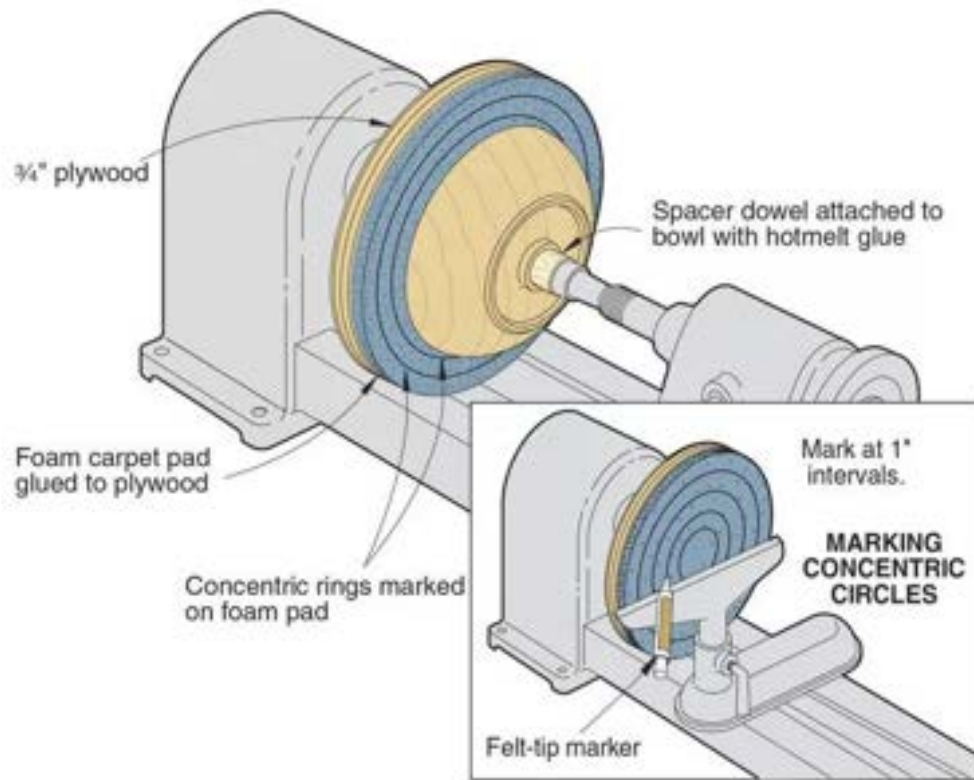

Starting about 2" from the center, I marked concentric circles at 1" intervals using a felt-tip marker, as shown in the inset drawing. The circles allow me to center bowls of different diameters on the foam-covered face of the plywood disc.

To mount a bowl, I use a dab of hotmelt glue to secure a short length of 1" dowel to the bottom of the bowl. The tailstock center fits against the dowel and holds the bowl firmly against the foam-covered disc. To complete the recess, I carefully remove the stock under the dowel, remove the piece from the lathe, and trim off the remainder with a sharp chisel.

See More: [Tested Tips for turners](#)

NOTE: Any websites or videos mentioned for inspiration are provided for informational purposes only and are not endorsed by the Island Woodturners Guild. Use your own discretion when visiting the websites and using techniques shown in videos. Always use safety gear.

IT'S YOUR TURN

We're on Social Media! Follow us on Facebook and Instagram. You can scan the QR code below or click the social media icon.



PARTING OFF

A special thanks to Ken Halstead for taking photos at our Show & Tell and to Sean Capstick for handling our audio/visual at the meetings and creating the videos for the Show & Tell on the website.

We are very encouraged to see the number of members attending our in person meetings and participating in the Show & Tell. We appreciate you!

CONCLUDING THOT

